



MOTORTRONICS™

Solid State AC Motor Control

Msmart

SMART-TCB Addendum



Table of contents

- 1 About the Smart TCB 3**
 - 1.1 General 3
 - 1.2 Connection Layout..... 4
 - 1.3 Terminals 5

- 2 Communication Connections..... 8**
 - 2.1 Communication Connection Smart TCB Board Hub 8
 - 2.2 Customer Communication Connections Smart TCB CPU Board 8

- 3 Board Connections 9**
 - 3.1 MVC4 Main Board Connections 9
 - 3.2 Smart TCB Connections to Contactors and Rings 10
 - 3.3 Fuse Ratings..... 10

- 4 Msmart Touch Screen 11**
 - 4.1 Startup 11
 - 4.2 Navigation and Settings..... 13
 - 4.2.1 Main Menu 13
 - 4.2.2 MVC Status / Setup Screen 14
 - 4.2.3 Msmart Settings 15
 - 4.3 Device Selection and Programming 16
 - 4.3.1 Device Selection 16
 - 4.3.2 MVC4 Programming 17
 - 4.4 Smart TCB Status and Programming 21
 - 4.4.1 Access Smart TCB Page 14 21
 - 4.4.2 Smart TCP Setpoint Pages 1- 10 21
 - 4.4.3 Relay Programming Example 26
 - 4.4.4 PFC Option Operation 32

- APPENDIX A: TECHNICAL SPECIFICATIONS 35**

- APPENDIX B: COMMUNICATION REGISTERS 36**

- WARRANTY INFORMATION 44**

1. About Smart TCB

1.1 General / Features

The Smart TCB is the next generation MVC4 TCB with advanced I/O and communication options. The Smart TCB interfaces with the Msmart touch panel as well as auxiliary devices.

The Smart TCB controls contactors, handled start command and updates status and trips of the starter.

In addition, the Smart TCB offers the user communication access using several different protocols over Ethernet as well a serial connection.

1.2 Smart TCB Connection Layout

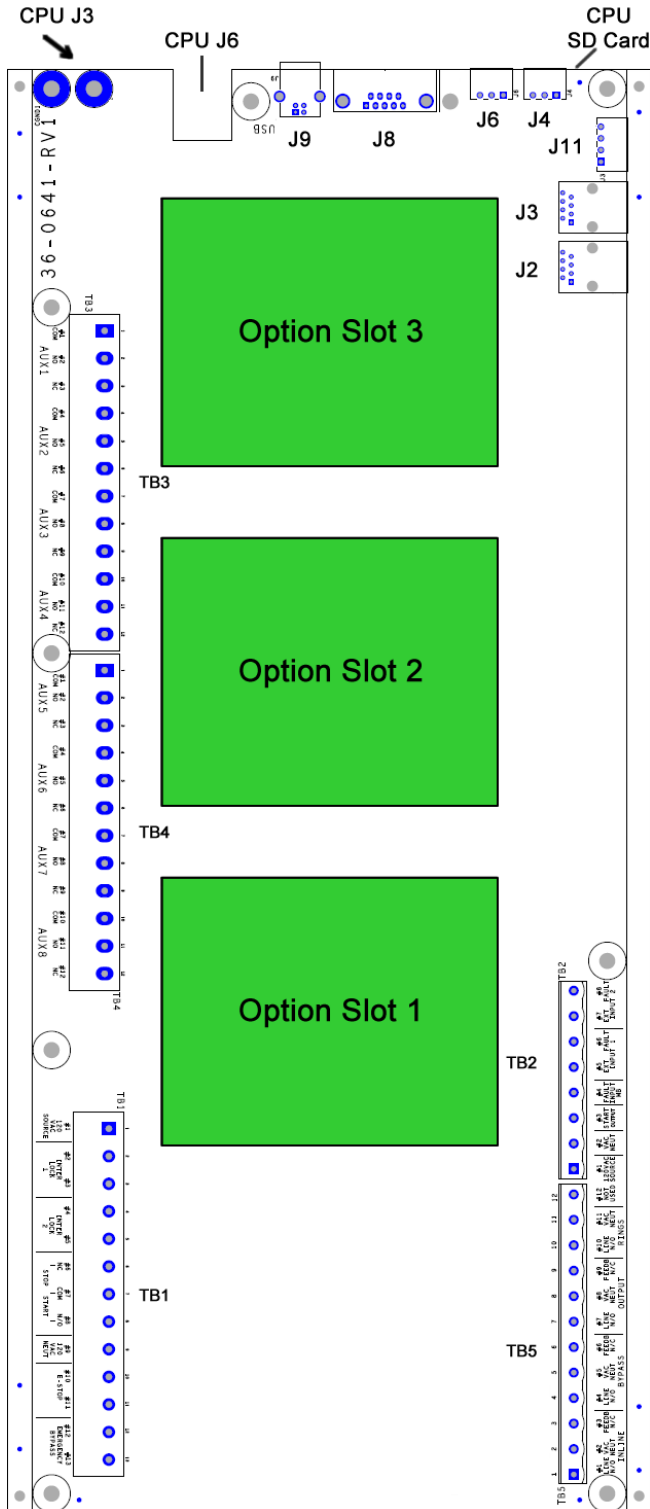

1.3 Smart TCB Terminals

TB1 Start / Stop Control		
T	Description	
1	AC	120 VAC Control Power (Line)
2 3	NC C	Shutdown Input – Accepts customer N.C dry contact (Factory jumper installed)
4 5	NC C	Shutdown Input – Accepts customer N.C dry contact (Factory jumper installed)
6 7 8	NC C NO	Terminal 6, 7 & 8;"2-wire control is connected to pins 6 & 8". Also; "For 3 wire control, connect the N.C. STOP button to pins 6 & 7 and the N.O. START button to pins 7 & 8
9	AC	120 VAC Control Power (Neutral)
10 11	C NC	E-Stop Select, Normally Closed
12 13	C NO	E-Bypass Select, Close a dry contact to select E-Bypass.

TB2 MB/CPU and Fault Connections		
T	Description	
1	AC	120 VAC Main Board Power (Line)
2	AC	120 VAC Main Board Power (Neutral)
3	-	Start CMD to the Main Board TB3-5
4	-	Fault from the Main Board TB1 – 2. NOTE: TB1 – 1 is connected to TB3 – 1 on the Main Board.
5 6	C NC	External Fault #1 – Normally Open – Close to Trip
7 8	C NC	External Fault #2 – Normally Open – Close to Trip

Description of Terminal Connections - Continued

TB3 Auxiliary Relays		
T	Description	
1 2 3	C NO NC	Aux Relay #1: Form C relay
4 5 6	C NO NC	Aux Relay #2: Form C relay
7 8 9	C NO NC	Aux Relay #3: Form C relay
10 11 12	C NO NC	Aux Relay #4: Form C relay

TB4 Auxiliary Relays		
T	Description	
1 2 3	C NO NC	Aux Relay #5: Form C relay Note: Relay used as TCB Trip to the MVC4 - CPU
4 5 6	C NO NC	Aux Relay #6: Form C relay
7 8 9	C NO NC	Aux Relay #7: Form C relay
10 11 12	C NO NC	Aux Relay #8: Form C relay

Description of Terminal Connections – Continued

TB5 Contactor and Ring Connections		
T	Description	
		INLINE CONTACTOR
1	L	120vac supply switched output to A1 of contactor
2	N	120vac Neutral to A2 of contactor and return side N.C, aux. contact on contactor.
3	-	Supply side N.C. aux contact on contactor. Provides feedback.
		BYPASS CONTACTOR
4	L	120vac supply switched output to A1 of contactor
5	N	120vac Neutral to A2 of contactor and return side N.C, aux. contact on contactor.
6	-	Supply side N.C. aux contact on contactor. Provides feedback.
		OUTPUT CONTACTOR
7	L	120vac supply switched output to A1 of contactor
8	N	120vac Neutral to A2 of contactor and return side N.C, aux. contact on contactor.
9	-	Supply side N.C. aux contact on contactor. Provides feedback.
10	L	120vac supply switched output to A1 of contactor
11	N	120vac Neutral to Rings
12	-	Not Used

2. Communication Connections

2.1 Communication Connections –Smart TCB Board HUB

Fuses	
#	Location
J2	RJ45 to the HMI (RS422)
J3	RJ45 to the MVC CPU
J4	RS485 (Non-Isolated). Connect slave devices, Terminal 1 = +, 2 = -, 3 = GND Address 1-10, baud rate 19.2kB, Data Bits: 8, Parity: None, Stop Bits: 1
J6	RS485 (Isolated). Connect slave devices, Terminal 1 = +, 2 = -, 3 = GND Smart TCB Address 17-246, baud rate 19.2kB, Data Bits: 8, Parity: None, Stop Bits: 1
J8	9-PIN SUB D Female for Bluetooth Adapter For use with MLink. Note: J8 & J9 cannot be used simultaneously
J9	USB Serial Port For use with MLink. Note: J8 & J9 cannot be used simultaneously
J11	Connector to MVC CPU TB4 (RS422) One to one connection from Smart TCB to MVC CPU

2.2 Customer Connections – Smart TCB CPU Board

Communication	
#	Location
J3	RS485 (Isolated). Connect slave devices, Terminal 1 = +, 2 = -, 3 = GND Smart TCB Address 4, baud rate 9600 Baud, Data Bits: 8, Parity: None, Stop Bits: 1
J6	Ethernet Port Modbus TCP Connection

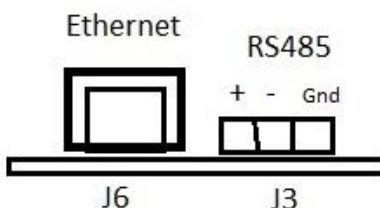

3. Board Connections

3.1 MVC4 Main Board Connection

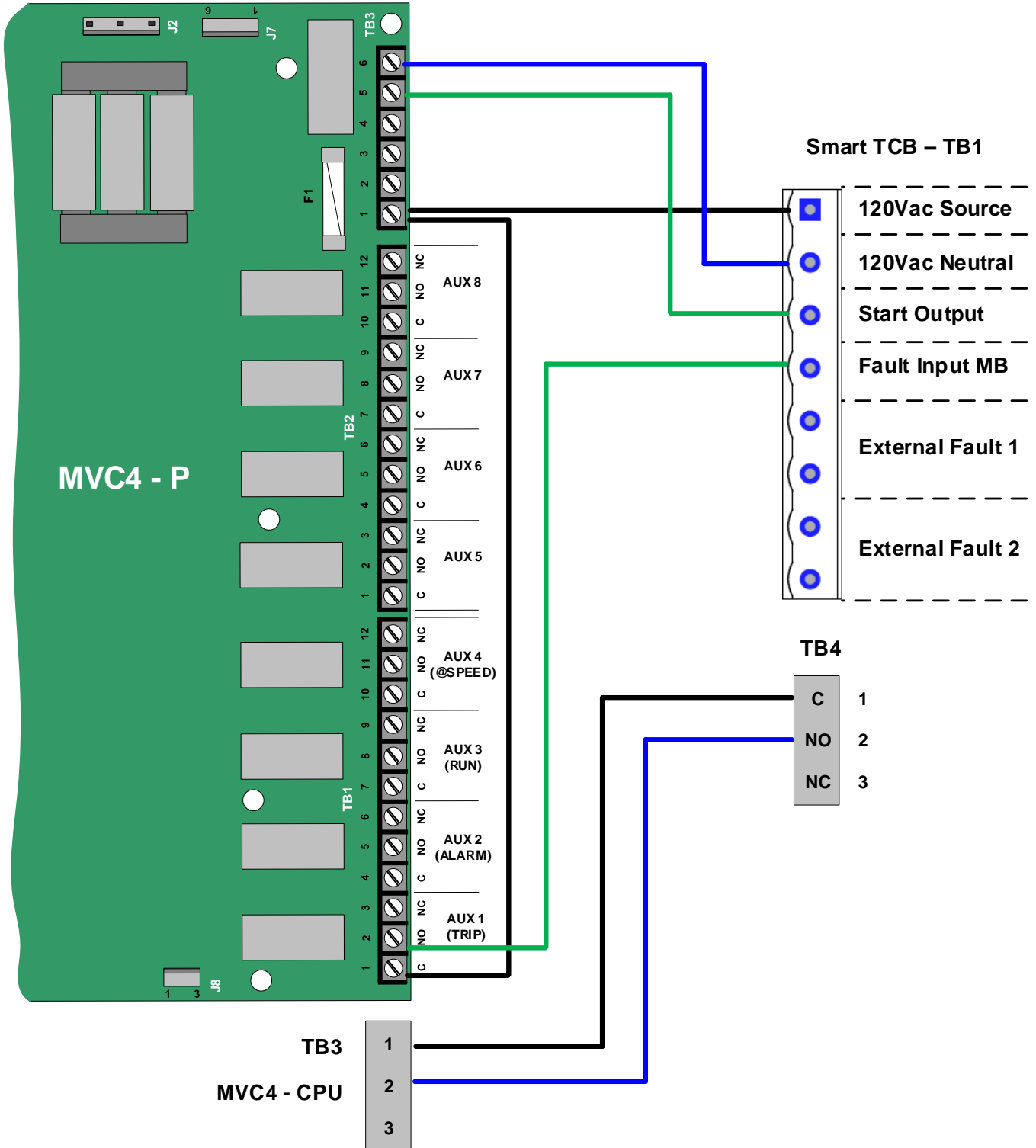

3.2 Smart TCB Connection (TB5) to Contactors and Rings

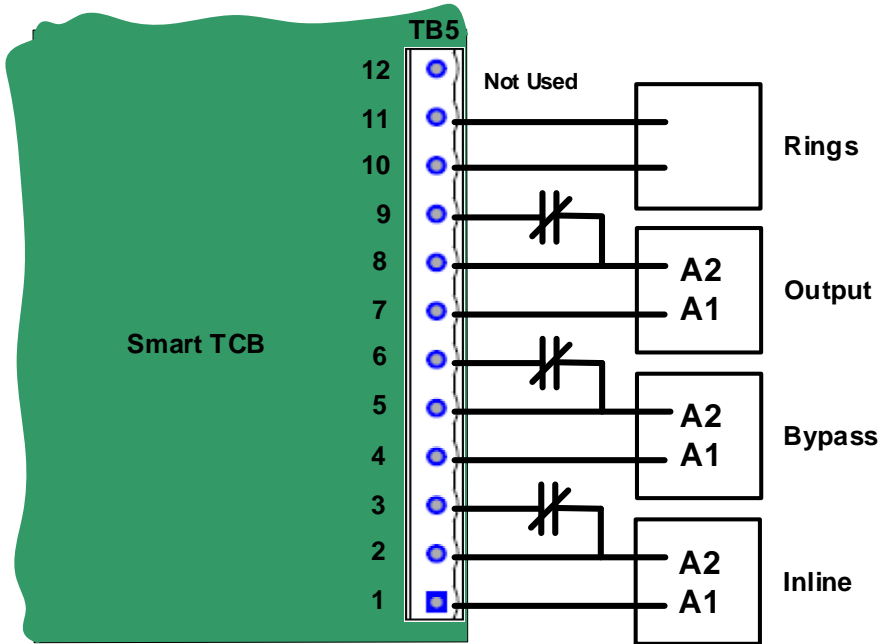

3.3 Fuse Ratings

Fuses		
FUSE	Location	Rating
F1	MAIN BOARD	1 AMP
F2	EXTERNAL FAULT POWER	1 AMP
F3	TB1 INTERLOCK & START/STOP POWER	1 AMP
F4	CONTACTOR & RING POWER	5 AMP

4. Msmart Touch Screen

4.1 Startup

Upon power-up the Msmart will show a splash startup screen with a status bar indicating the Msmart startup status.

Next the Msmart touch screen will attempt to communicate with the MVC and additional devices. The online status is shown on the top of the screen. Green indicates device is communicating properly and red indicates communication cannot be established with the device.



Msmart Splash Screen

Msmart consist of a touchscreen and four membrane buttons for navigation that can be used when the system is installed in a harsh environment.

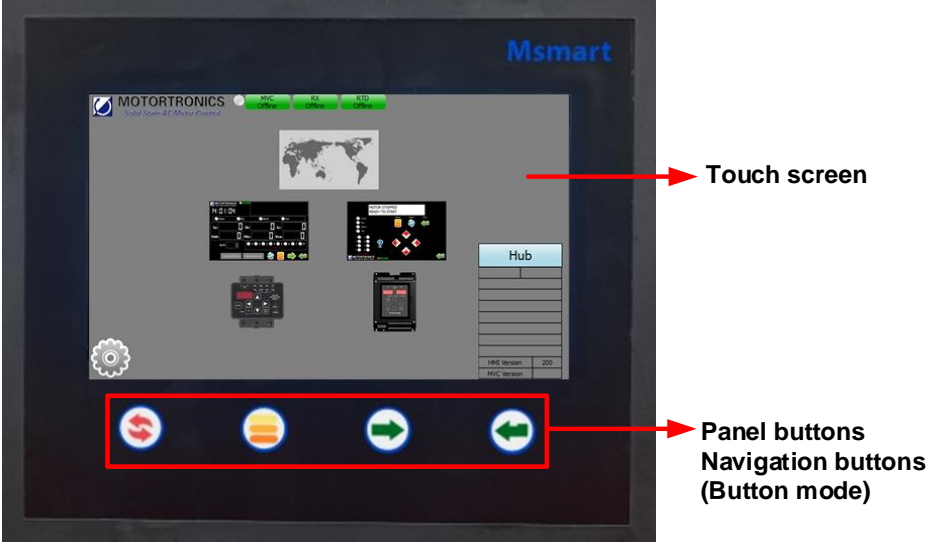

Msmart Touch Screen





Hardware Push Button Description		
Button		Resets the device on the screen only. Also resets the Msmart display by holding button for 6 – 10 sec.
		Switch between touchscreen and panel buttons (button mode). Menu icon will flash when panel buttons are active.
		Button used to move between selectable items on the touchscreen (forward Tab). The item will flash when selected.
		Select flashing item.

Table 2

4.2 Navigation and Settings

4.2.1 Main Menu

After powerup Msmart will display the main menu navigation screen. The main menu allows the users to monitor and program all devices connected to Msmart system.

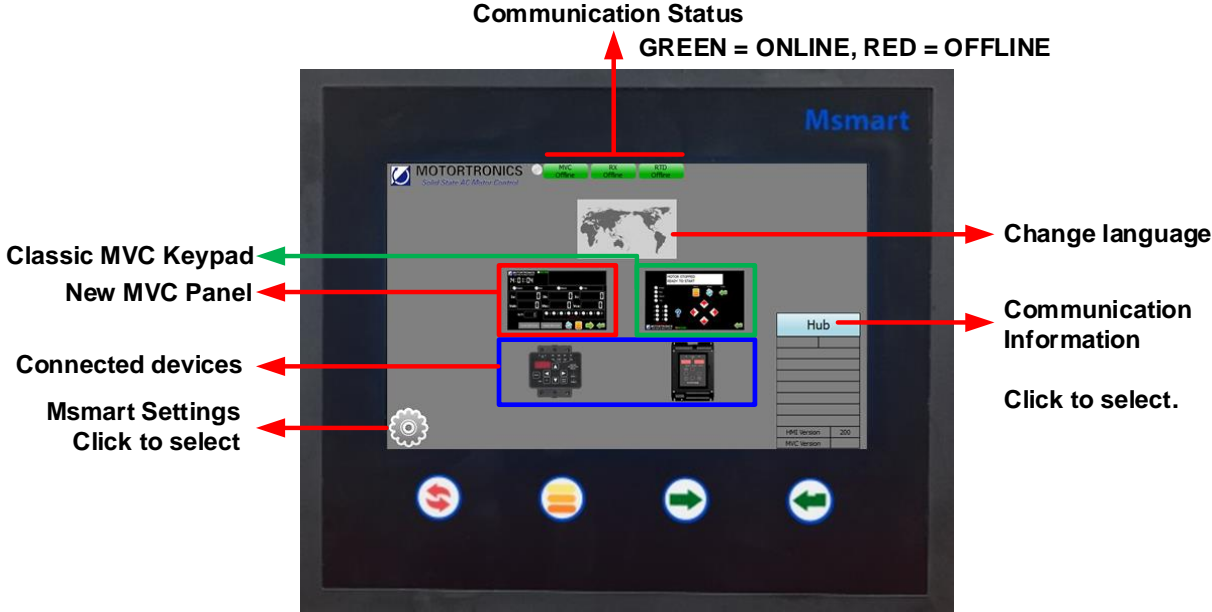

Note: The RX Motor Protection and TE-RTD12 are optional devices

Communication status

The communication status indicators at the top of the screen indicate if the Msmart is communicating successfully with the connected devices. Green means communication is ok, red for communication lost.

Communication Information

- Click to display specific information about
- TCB communication connection.
 - RS232/RS422/RS485 communication

4.2.2 Main MVC Status / Setup Screen

The status screen shows current operation status and includes:

- Alarm and trip status
- Phase current and voltages
- Auxiliary relay status
- Starting curve for voltage and current
- MVC setpoint and metering page success

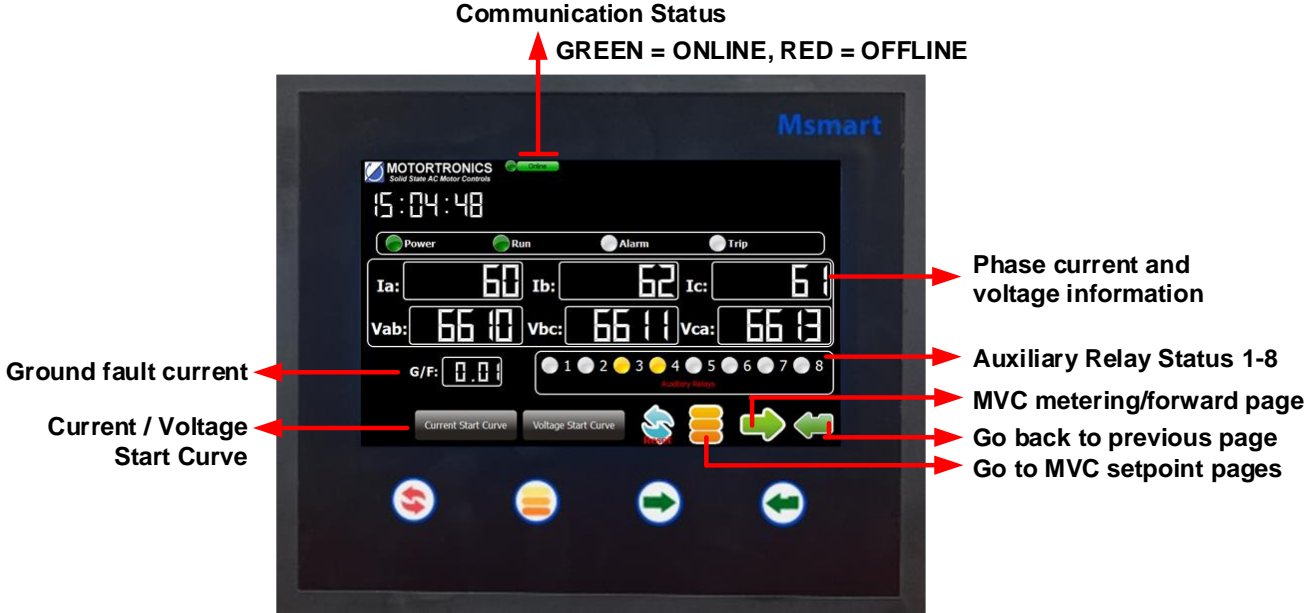

The MVC setpoint pages can be accessed by pressing the  button. See chapter MVC programming for more information.

The MVC metering pages can be accessed by pressing the  button. See chapter MVC metering for more information.

4.2.3 Msmart Settings

Click on the gear tooth icon  to view/change the Msmart touch screen settings.

The following settings can be adjusted:

- Main page background color
- Backlight brightness
- Beep sound
- Save delay time
- Return delay to main menu

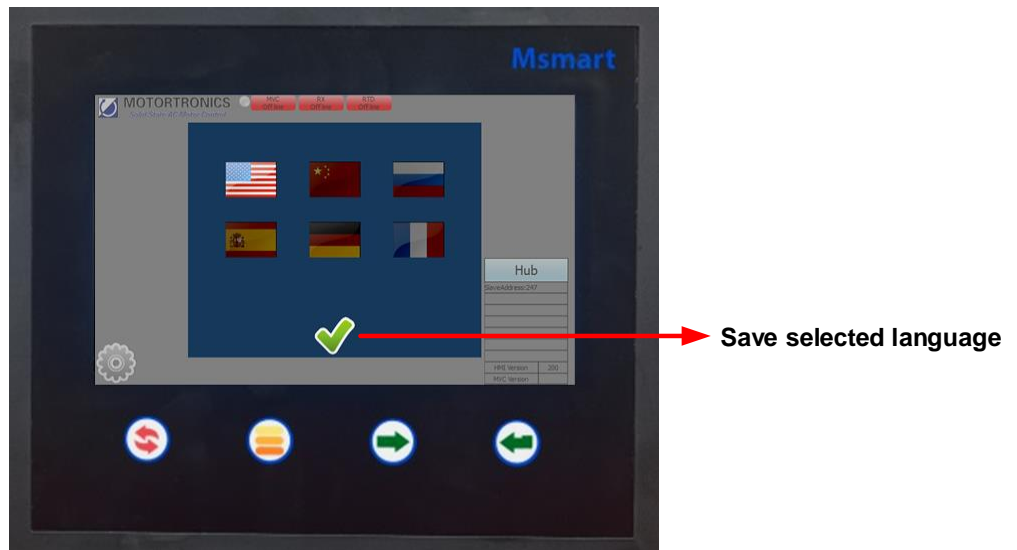
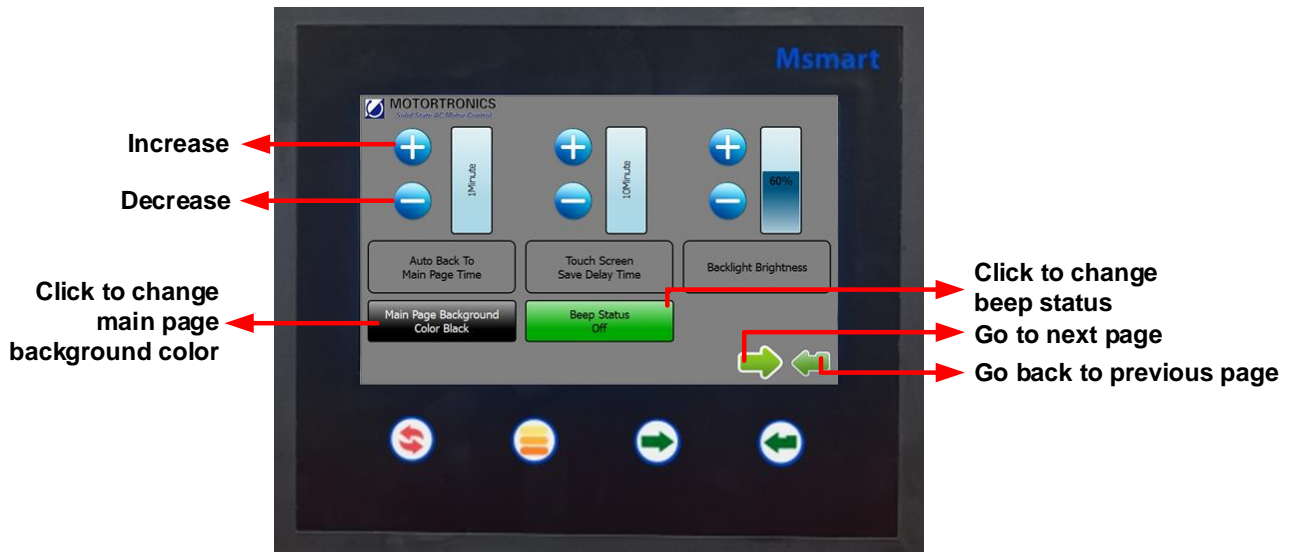

4.3 Device Selection and Programming

4.3.1 Device Selection

Depending on the Msmart system configuration all available devices will be displayed on the main menu page.

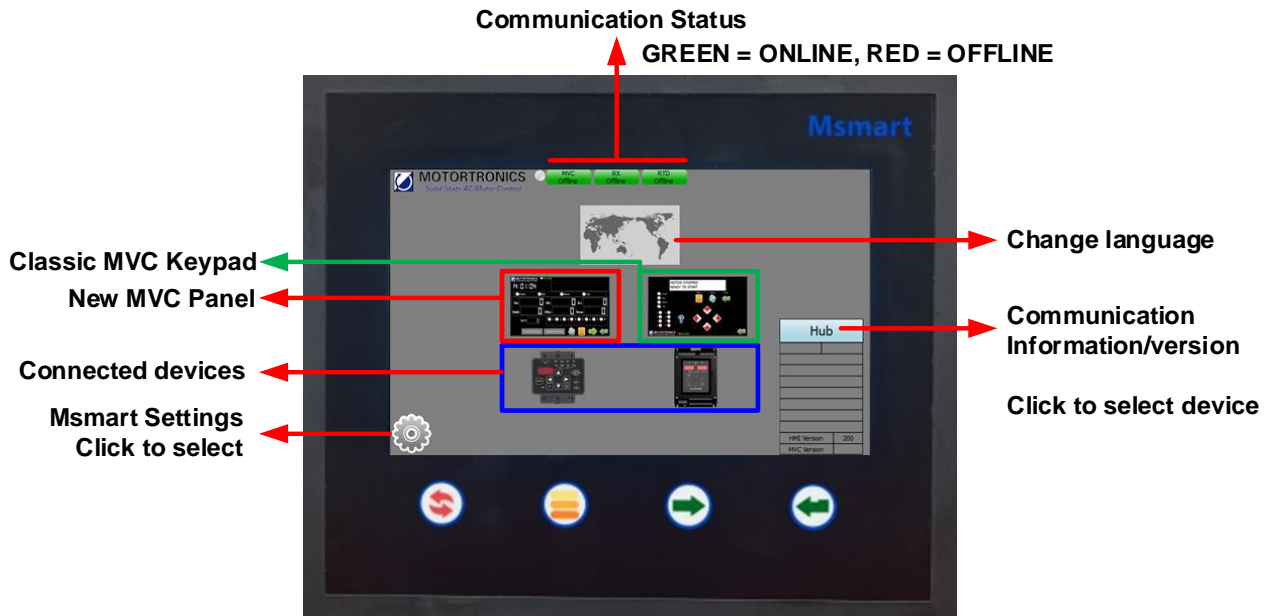

Navigation Keys (Button mode)

Use touch screen or dedicated keys on the Msmart touch screen to select device.

4.3.2 MVC4 Programming

The Msmart touch panel offers the user 2 way to program the MVC4 soft starter.

1. Use direct setpoint pages
2. Use Virtual MVC4 Keypad

#1: Access MVC Setpoint Pages Direct

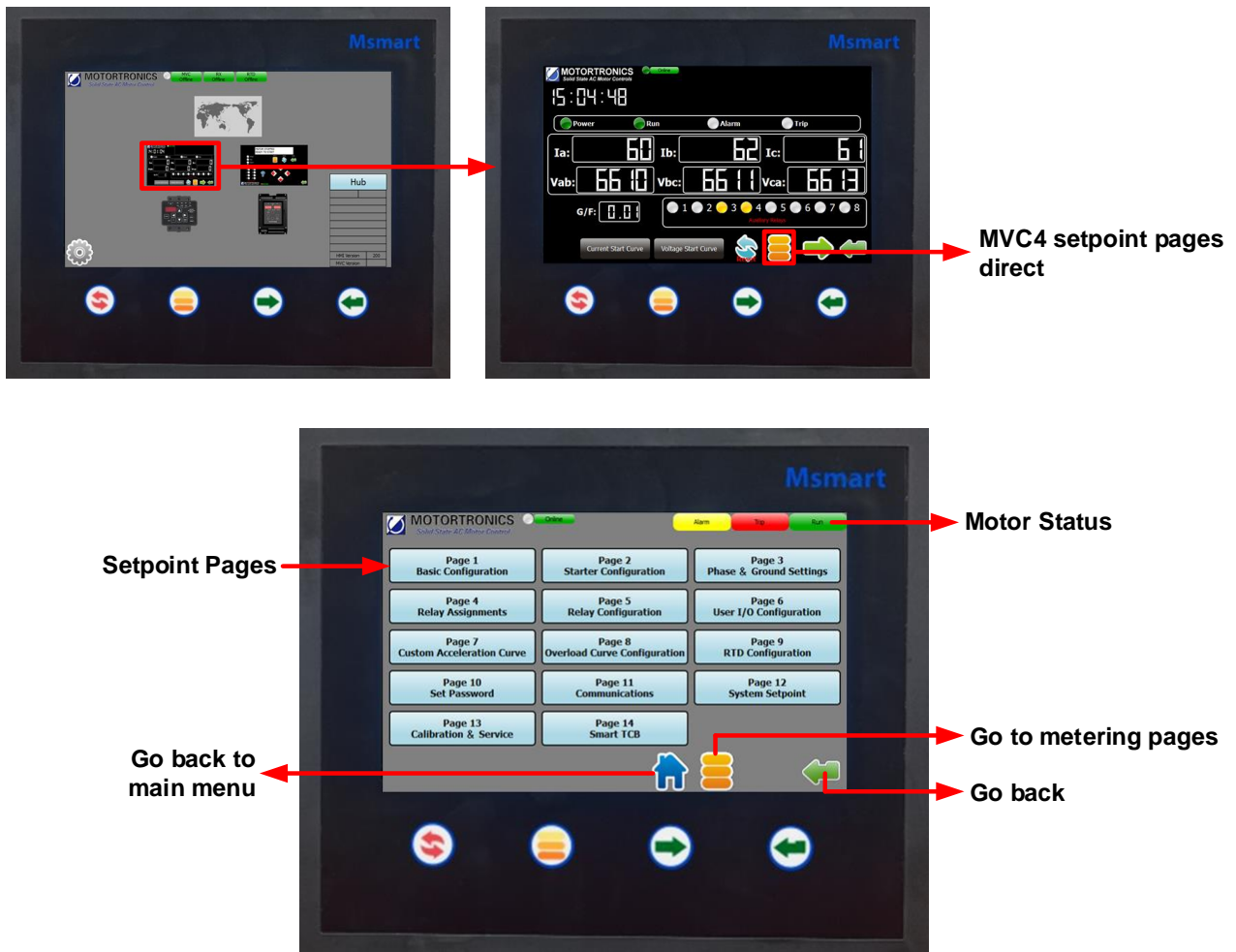

#1 Select setpoint page to view parameters direct

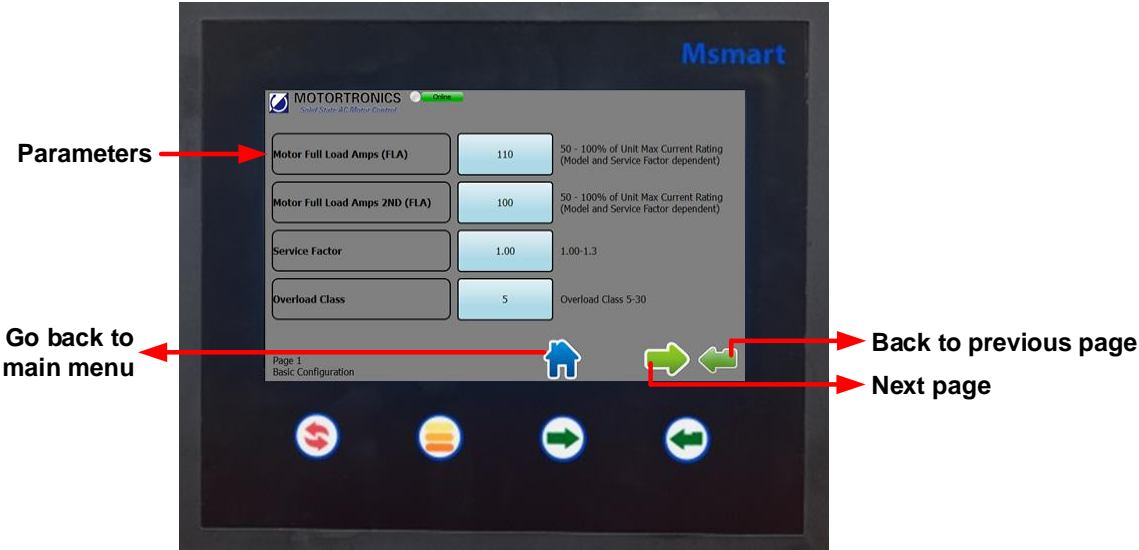

Change parameter settings

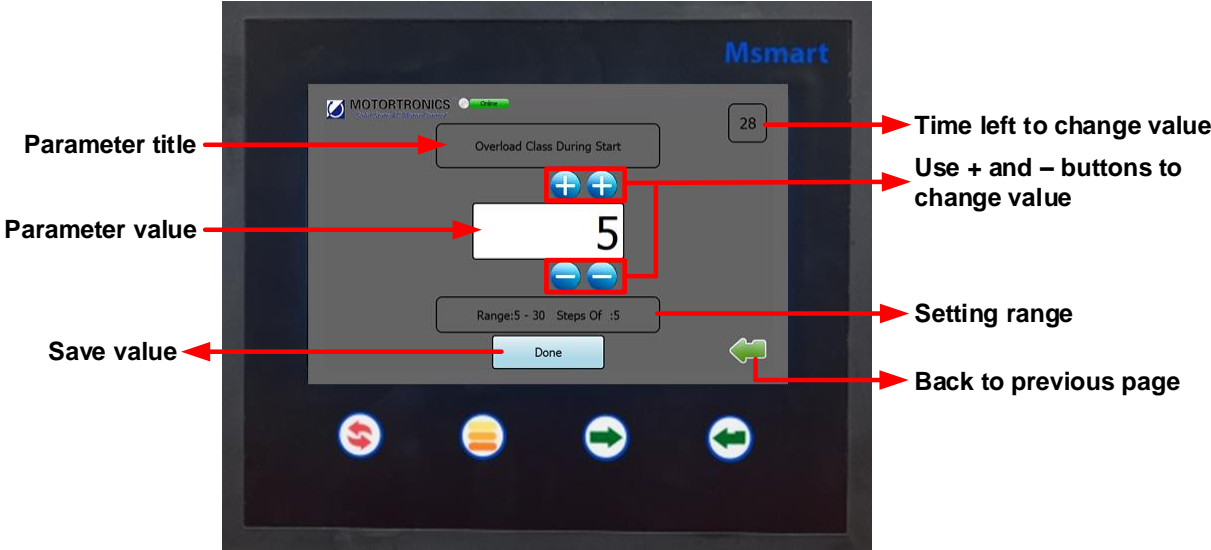

Click "done" button to save value

#2: Using the MVC4 Virtual Keypad

Click on the Classic MVC4 keypad in the Msmart main menu.

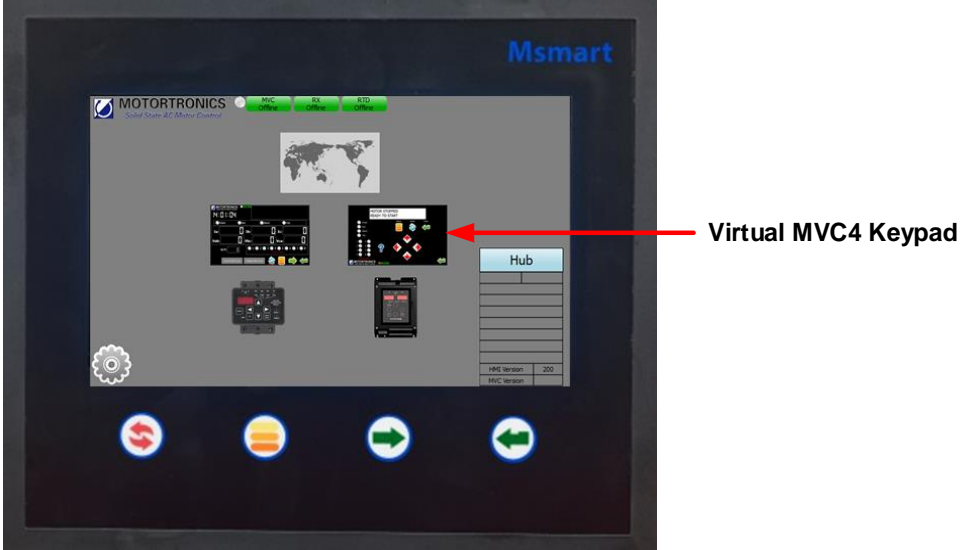

#2 Virtual MVC4 keypad

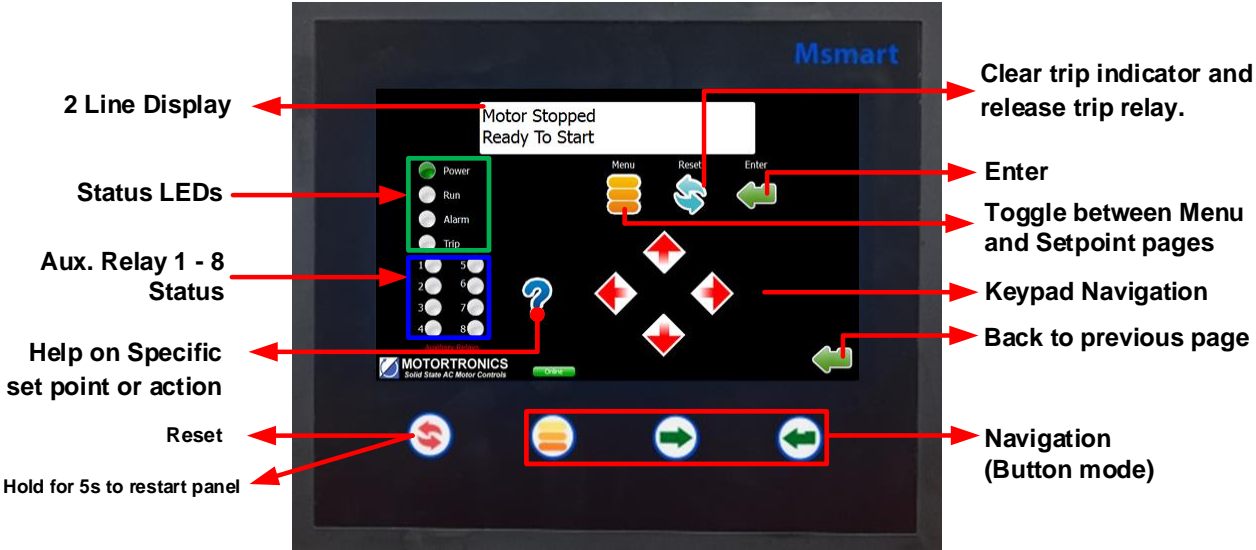

#2 Virtual Keypad/Operator Interface

The virtual keypad/ operator interface consists of:

- 2 rows of 20 characters
- 12 indicator LEDs
- 8 buttons

Note: The soft starter is menu driven and there are three levels of programming. The programming for two of these levels is password protected. Level two requires a three-digit password and level three requires a four-digit password.



Virtual Keypad Operator designations and functions

ITEM	DESIGNATION	DESCRIPTION
KEY	MENU	Toggle between the menu selection for metering and set point pages.
	RESET	Will clear the trip indicator and release the trip relay.
	ENTER	Pressing the ENTER button once enters the EDIT mode where set point values can be changed. An "Asterisk" will appear on the display to indicate it is in the edit mode. After a set point value is changed, pressing the ENTER button again will save the revised value to memory and the asterisk will go off indicating the change has been saved. When not in the edit mode, the ENTER pushbutton will toggle through the event indicator list (such as alarms or trips)
	HELP	Provides general help information about a specific set point or action.
	UP ARROW	Will scroll up through the set point and metering menu page. It will scroll to the top of the set point page or a section. In edit mode it will increase a set point in an incremental step or toggle through the available options in the set point.
	RIGHT ARROW	In the main menu the RIGHT ARROW button provides access to the set point page. For set point pages with multiple columns, the RIGHT ARROW will scroll the set point page to the right. When in edit mode it will shift one character to the right.
	DOWN ARROW	Will scroll down through the set point pages and down through the set points. In edit mode, it will decrement through values and toggle available options in the set point.
	LEFT ARROW	Will move to the left through set point pages with multiple columns. When in edit mode it will become the backspace key and will shift one character to the left.
LED	POWER	Indicates control power is present
	RUN	Indicates unit/motor is running
	ALARM	Lights in conjunction with Relay AUX 2 to indicate an Alarm event or warn of possible critical condition.
	TRIP	Lights in conjunction with Relay AUX 1 to indicate a Trip condition has occurred.
	AUX 1- 8	Auxiliary relays (Note: Relays 5-8 are available for customer use)

See MVC4 User Manual for details on faults, alarms, monitor and setpoint pages

4.4 Smart TCB Programming

4.4.1 Access Smart TCB Page

Select MVC status panel in the Msmart main menu.

#1: Access Smart TCB Page 14

Click on Page 14 Smart TCB to go to the Smart TCB status page.

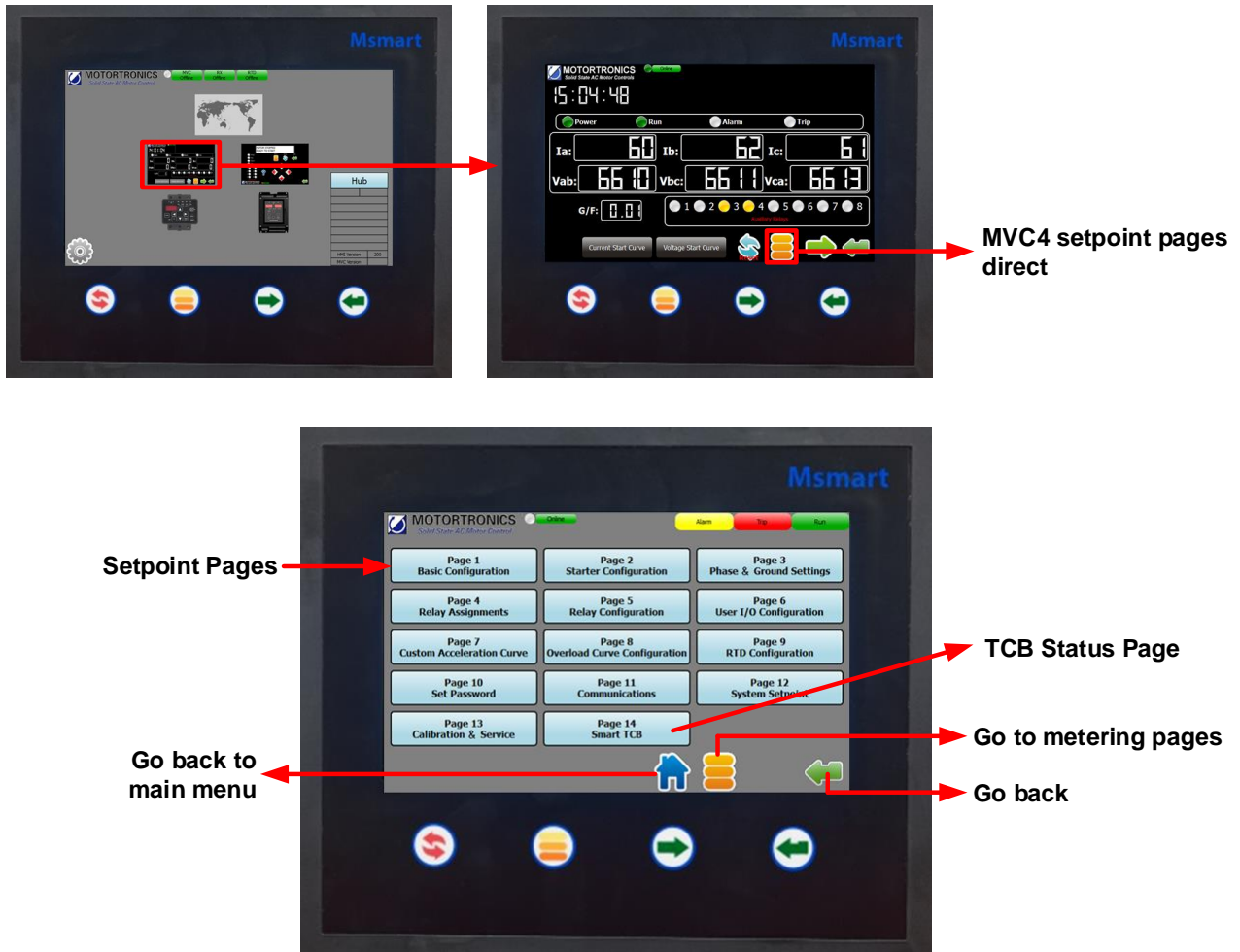

TCB Status Page

Page 1 displays the status of the inputs and outputs of the Smart TCB and the status and settings of the eight programmable relays on the board.

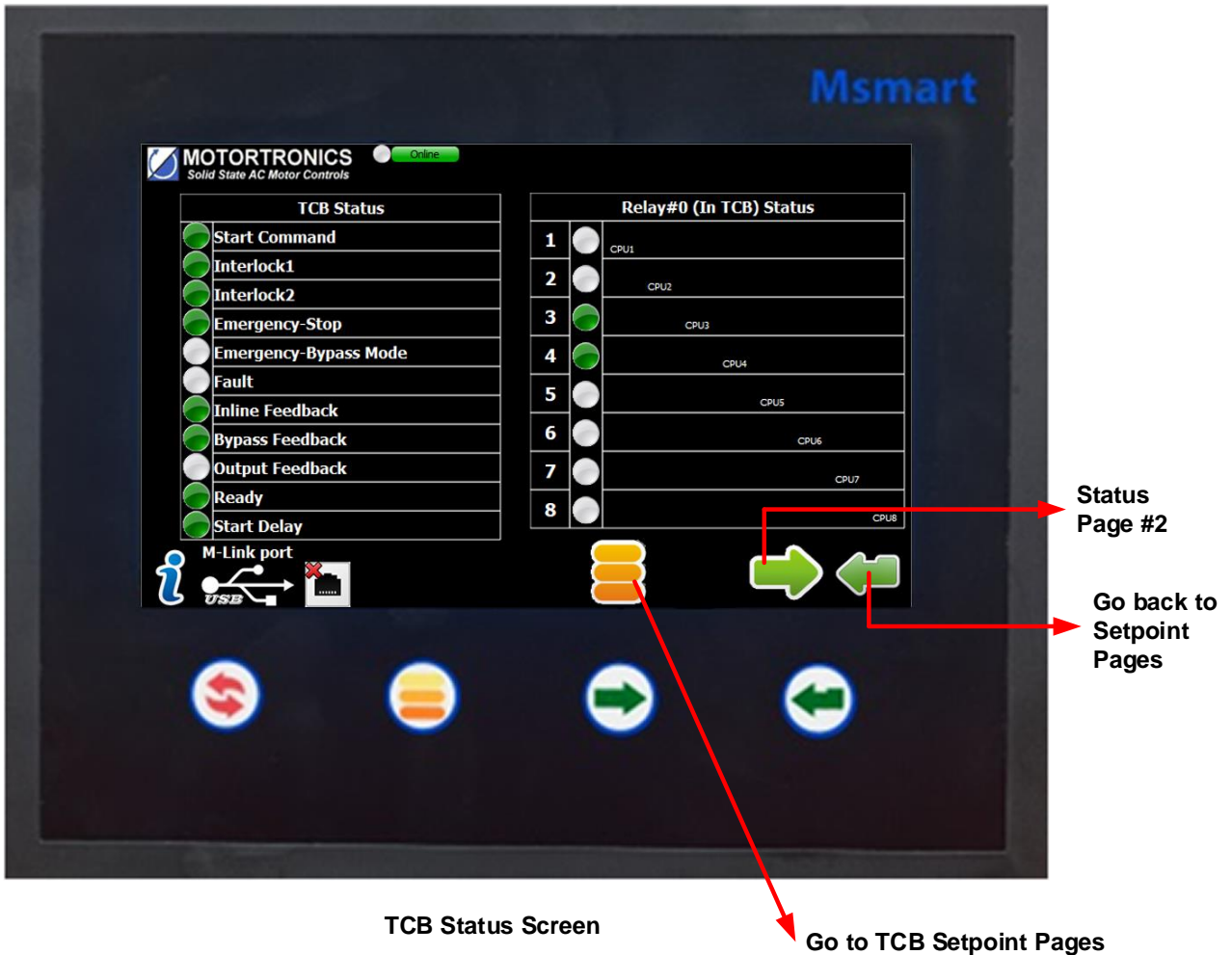

TCB Status Screen

Go to TCB Setpoint Pages

TCB Status		
Status	Interlock #1	Green when Interlock is Closed.
	Interlock #2	Green when Interlock 2 is Closed.
	Emergency Stop	Red when this mode is selected.
	Fault	Red if there is a Fault.
	Inline Contactor	Green when the inline is closed.
	Bypass Contactor	Green when the Bypass is closed.
	Output Contactor	Green when the Output is closed. (If flashing no Contactor Mode has been selected.)
	Ready	Green when Ready.
	Start Delay	Green when the start delay time is over.
	Ethernet port	Red "X" if not active.
	M-Link port	Port type selected.

TCB Status Page #2 (continued)

Page 2 displays the status of Option Slot 1 and 2.

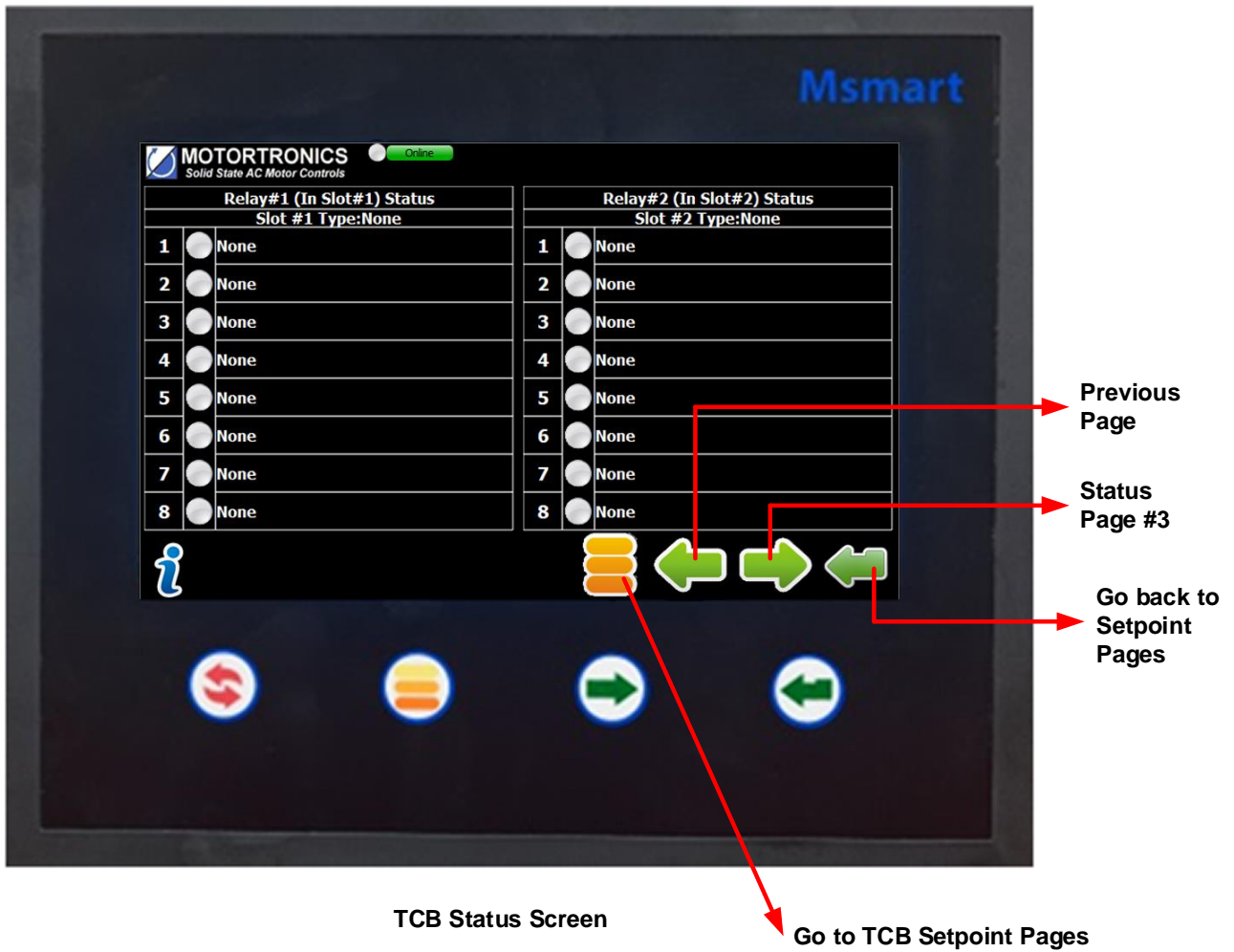

TCB Status Page #3 (continued)

Page 3 Displays the the status of Option Slot 3 and the time remaining on the programmable timers.

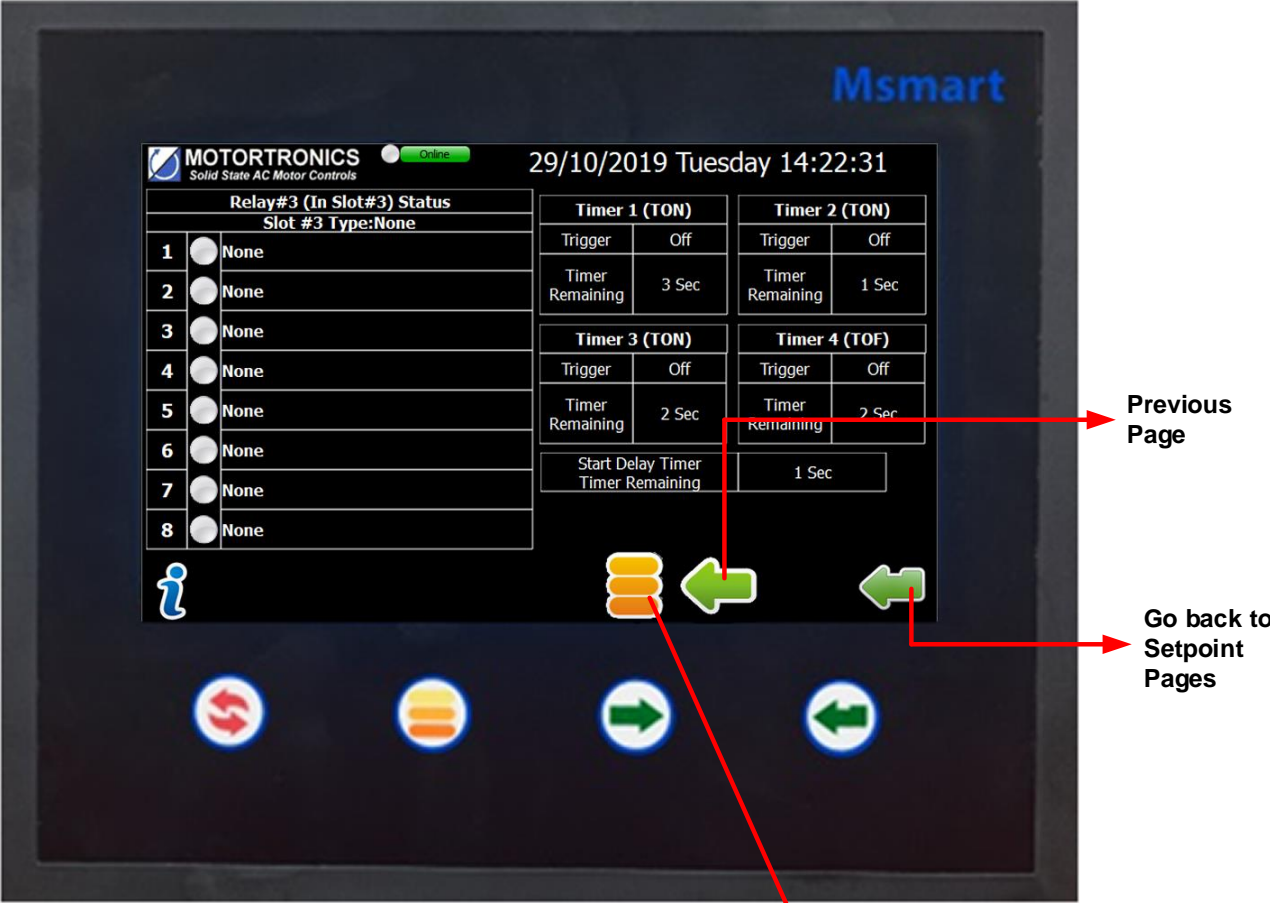

TCB Status Screen

Go to TCB Setpoint Pages

TCB Setpoint Pages

This TCB Setpoint Page overview shows the separate TCB pages. Click on any of the pages to setup dedicated section of the Smart TCB.

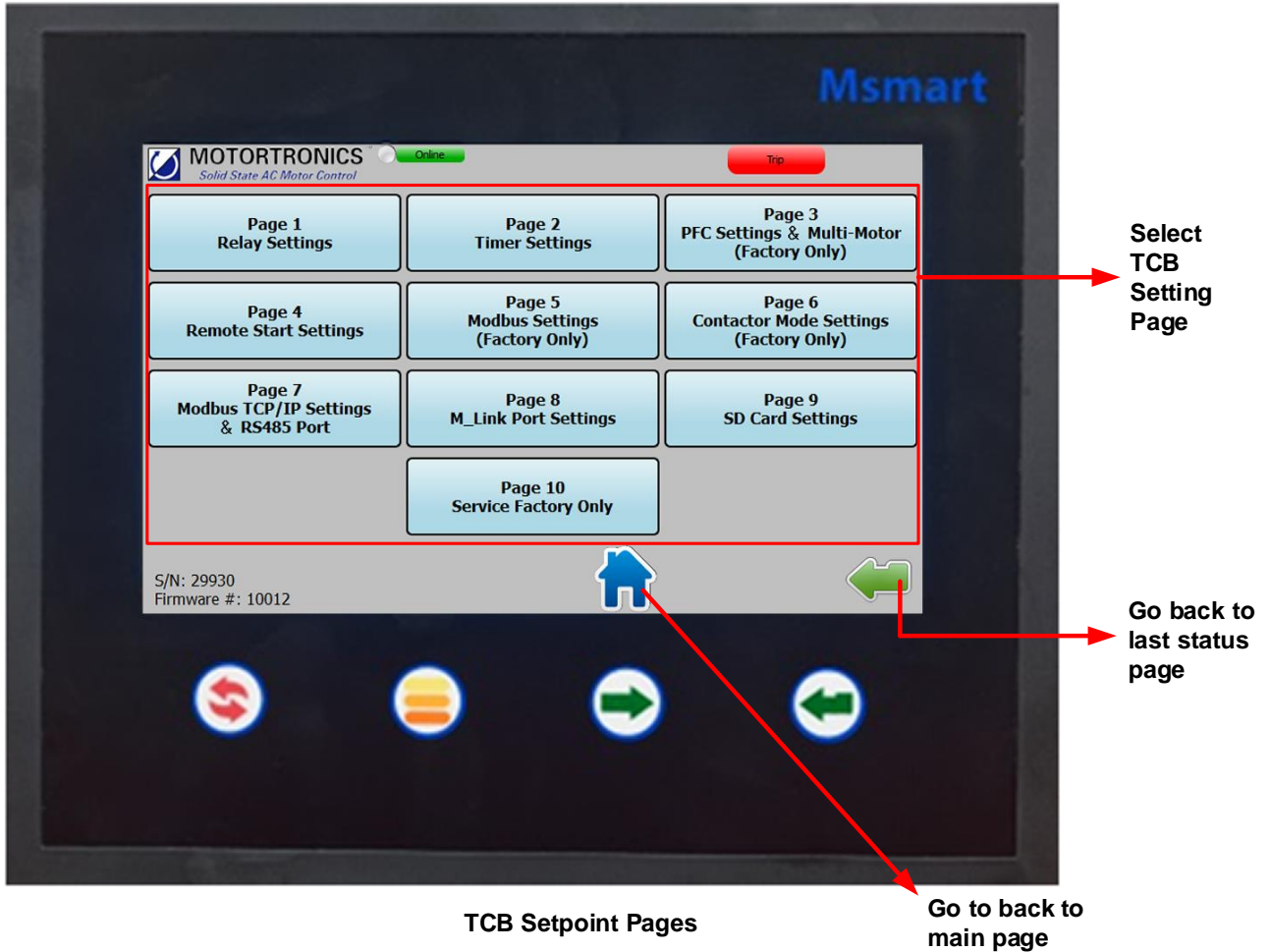

See next page for setpoint page information.

4.4.2 Smart TCB Setpoint Pages 1 -10

Page 1: Relay Settings (1-8)

Page 1-1 Program settings for the relays on the Smart TCB board.

Total of 8 Relays, select from 16 settings for each relay.

NOTE: Aux Relay 5 is used by the factory and should not be changed.

Relay #	Default Setting
1	CPU Aux 1 Fault
2	CPU Aux 2 Alarm
3	CPU AUX 3 Run
4	CPU Aux 4 At Speed
5	Ext. Fault (do not change)
6	CPU Aux 6
7	CPU Aux 7
8	CPU Aux 8

Page 1-2 Program settings for Slot #1 option relays on the Smart TCB.

Total of 8 Relays, select from 16 settings for each relay.

Page 1-3 Program settings for Slot #2 option relays on the Smart TCB.

Total of 8 Relays, select from 16 settings for each relay.

Page 1-4 Program settings for Slot #3 option relays on the Smart TCB.

Total of 8 Relays, select from 16 settings for each relay.

Page 1-5 Program settings for Programmable Aux selection that can be selected for any relay on the Smart TCB.

NOTE: CPU settings mirror the setting of the MVC4 CPU.

Relay Settings

Fault	CPU Aux 1 Fault
Inline	CPU Aux 2 Alarm
Bypass	CPU AUX 3 Run
Programmable Aux* (see table below)	CPU Aux 4 At Speed
Timer 1	CPU Aux 5
Timer 2	CPU Aux 6
Timer 3	CPU Aux 7
Timer 4	CPU Aux 8

Auxiliary Settings

Ethernet Link Active	On-Off by Modbus 3002
Start to CPU	Ready
PFC Enable	

Page 2: Timer Settings

A total of 5 timers are available:

- 3 Delay on Make (TON)
- 1 Delay on Break (TOF)
- Start Delay (TON)

Timers control the AUX relays as selected in Page #1, Relay Settings.

Page 2-1 Program setting for timer #1 and #2, both TON.

Set the trigger and time for timer #1 and #2.

Page 2-2 Program setting for timer #3 (TON) and #4, (TOF).

Set the trigger and time for timer #3 and #4.

Page 2-3 Program setting for Start Delay timer, TOF.

Set the trigger and time for the start delay timer.

Timer Triggers (Start of Timing): Start, Run, At Speed, Inline, Bypass.

Setting #	Trigger
1	Start
2	Run
3	At Speed
4	Inline
5	Bypass

Page 3: PFC and Multi Motor Settings

Factory only settings page

Page 4: Remote Start Settings

Page 4-1 Select Remote start settings and Protection when in E-Bypass.

Remote control using communication:

Function	Address #	Data Value	INTERLOCK #2 Input
Stop	3000	0	Closed
Start	3000	Value of register 3001	Closed

Enabled, send a data value 1 to address 3000 to Start, send a 0 to stop.

Communication sequence:

To Start, read address 3001. Next send the data value read from address 3001 to 3000.

To Stop send a 0 to 3000.

NOTE: The data value in register 3001 changes for each start.

Local / Remote Control

Switch between local/remote operation using a switch connected to INTERLOCK #2

Switch	Function
Open	Local
Closed	Remote

Page 5: Modbus Settings

Factory only settings page

Page 6: Contactor Mode Settings

Factory only settings page

Page 7: Customer Modbus TCP/IP and RS485 Settings

Page 7-1 Set Ethernet IP, Subnet, Gateway, DNS1, DNS2.

Page 7-2 Select DHCP or Static. RTD installed on the MVC4 CPU. RS485 Modbus address and Baud rate.

TCB CPU Board:

Connector J3: Three pin isolated terminal block for RS485 Modbus RTU communication.

Connect Modbus devices (e.g. TE-RTD12, RX) to pin 1= +, 2 = -, 3 = Gnd.

Default settings: Modbus Address is 4, Baud Rate is 9600.

Connector J6: Ethernet connection for Modbus TCP/IP.

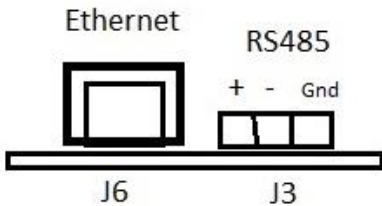

Page 8: MLink Port Select

Set USB or Optional Bluetooth communication for MLink.

NOTE: Baud rate is fixed at 115200.

Page 9 SD Card Data Logging Settings:

Page 9-1 Turn logging ON/OFF, set time sample time and data to log.

Page 9-2 Playback data-log.

The data log includes the Log Number, date and time, Current, Voltage, Start status, Inline status, Bypass status, Fault Status, PLUS Data 1, Data 2, and Data 3 selected from the table below.

#	Data Log Signal
1	Last CPU TRIP
2	Hottest RTD (if Installed)
3	PFC Status (if Installed)
4	Interlock #1 Status
5	Interlock #2 Status
6	E-Stop

Page 10: Service

Factory only settings page

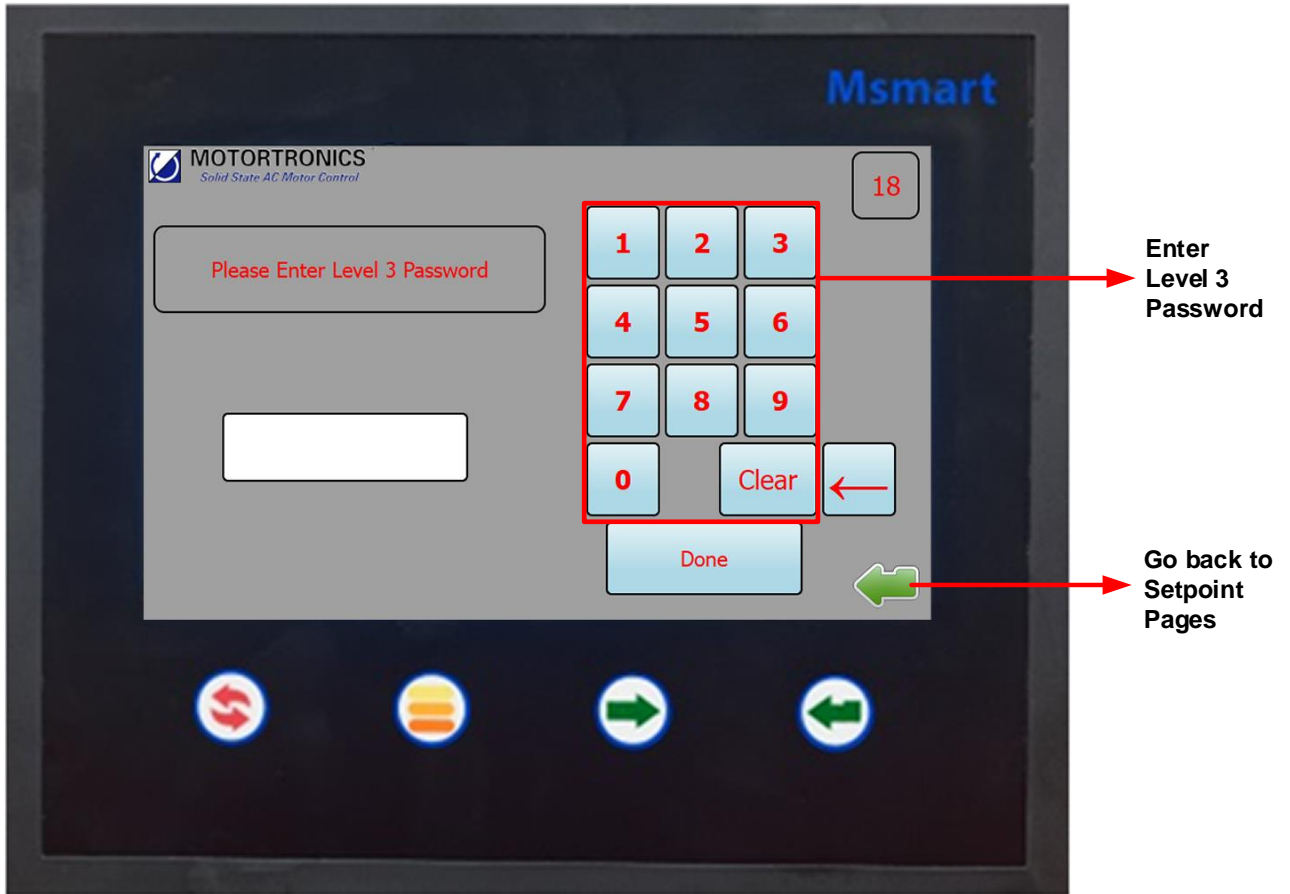

Access TCB Access Page

4.4.3 Relay Programming Example

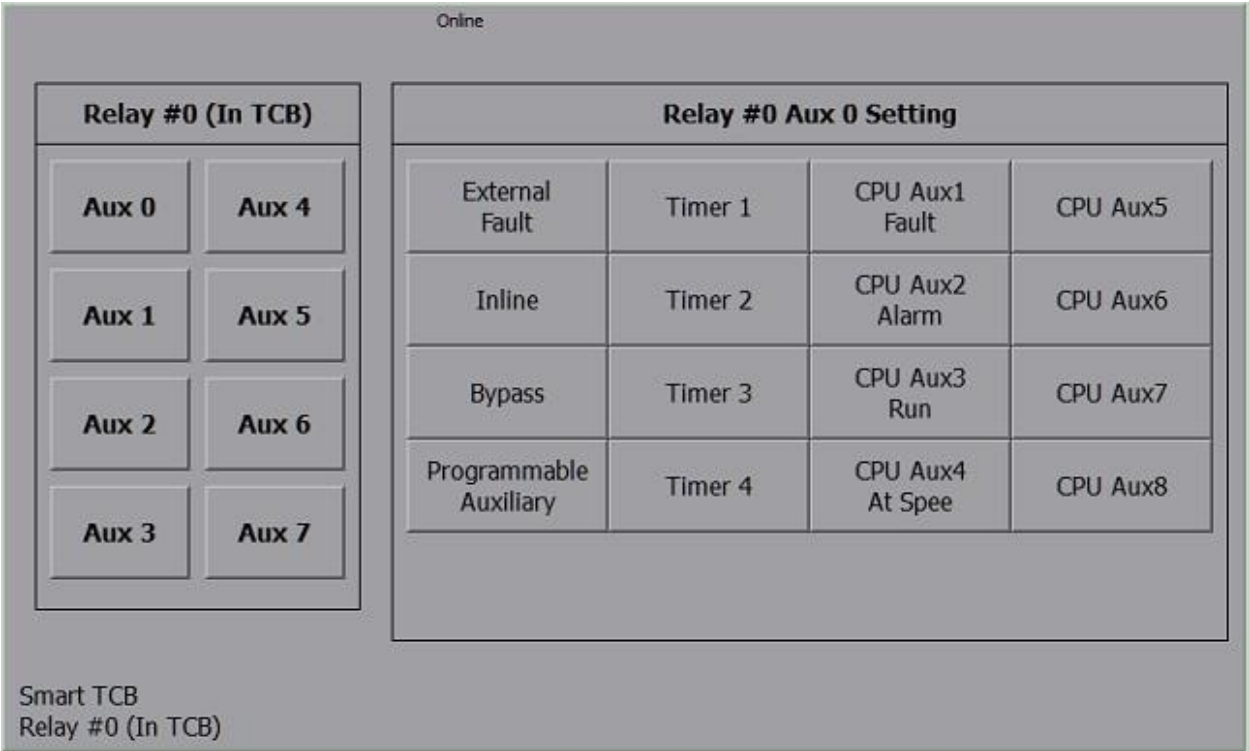

TCB Faults:

On the main TCB Status page a Fault page will pop up when there is a Fault. This page can also be displayed by touching the upper right corner of the screen.

TCB Faults	
Com Fail	Fault Interlock 1
Fail Inline	Fault Interlock 2
Fail Bypass	EXT Fault
Fail Output	E-Stop
Fail Multi	Power Up
Fault PFC Time	Contacto Check
Fault Incomplete	
Fault Start Ready	

NOTE: If only "EXT Fault" is shown the trip was caused by a device other than the TCB. Check the MVC4 display and any other external devices for trips (RTD12, RX5, etc.).

4.4.4 PFC OPTION Operation

Online

PFC Control	Master	Off , One Unit Multi-Unit , Master
Number Of PFC Units	6	1-10
PFC Off Interval Time	5	1-60 Sec
PFC On Interval Time	5	1-60 Sec

Smart TCB
PFC Functions

Online

PFC Address	1	1-10

Smart TCB
PFC Functions

The PFC Option allows switching of PFCs off during the start and back on after the start of starters in a line-up.

The PFC option Card is installed in one of the three option slots, slot two is the preferred slot.

Basic Operation:

1. Each Starter has an Address. (PCF ADDRESS)
2. Any starter in the lineup can request a start and sends a request for all starters to turn off the PFC's.
3. Each starter turns off its PFC based on, $PFC\ ADDRESS \times PCF\ OFF\ INTERVALTIME$.
4. When all PFC's are Off the starter will start.
5. At the end of the start the requesting starter will send a command to turn all PFC's back on.
6. The turn on time for each starter is the $PFC\ ADDRESS \times PCF\ ON\ INTERVALTIME$

PFC Option Board Connections:

1. TB1-1 and 2 a Dry AUX N.O connects here from the PFC Contactor.
2. TB1-3 and 4 120VAC used to power the PFC contactor connects here, 3 is Line and 4 is Neut.
3. TB1-5 and 6 are the PFC contactor coil connections, 5 is A1 and 6 is A2.
4. J2 is the PFC RS485 COM connections: 1 = Pos. +, 2 = Neg. -, 3 is COM Gnd. These are connected in series to each starter. The X1 resistor jumper should be over the two pins on the first and last starter. If a shielded cable is used the shield should be grounded at one end only to the earth ground, not the COM GND.
5. TB2: The PFC Option Board also has four AUX relays that program the same as all other AUX relays. Connection to the relays are on TB2.

PFC Programming:

1. **PFC CONTROL:**
 - ONE PFC: Use for one starter only.
 - MASTER: Use for more than one starter, use the RS485 com on the option board.
 - MULTI-UNIT: Use for more than one starter, use Ethernet Com.
2. **NUMBER OF PFC UNITS:** Set the number of starters with PFC options.
3. **PFC OFF INTERVAL TIME:** $PFC\ ADDRESS \times PFC\ OFF\ INTERVAL\ TIME =$ contactors opens.
4. **PFC ON INTERVAL TIME:** $PFC\ ADDRESS \times PFC\ ON\ INTERVAL\ TIME =$ PFC contactor closes.
5. **PFC ADDRESS:** Each Starter is given a different address number.

EXAMPLE: Starter timing from start command to starting:

Number of starters: 3.

PFC ADDRESS: 1, 2 and 3

PFC OFF TIME INTERVAL: 1 second on all starters.

Time to open PFC:

- Starter 1 = 1 Sec X ADDRESS 1= 1 Sec.
- Starter 2 = 1 Sec X ADDRESS 2 = 2Sec.
- Starter 3 = 1 Sec X ADDRESS 3= 3 Sec.

Request: Starter 2 Request a start, Starter 3 is running:

Starter 2 sends PFC OFF request = 5 seconds (this time is fixed) + Highest ADDRESS running starters off time, Starter 3 = 3 Seconds + Any Start Delay set in requesting starter = 1 Second = 9 Seconds, at this time the run delay light will come on and the start begins.

AUX Lights on the Option Slots Pages:

AUX 1-4: Indicates relay operation of the four AUX relays on the PFC Option Board if used.

AUX 5 Light: PFC DATA OUT, Flashes as data is sent. ON = Line is Low.

AUX 6 Light: PFC Tx or Rx Selected. ON = Tx.

AUX 7 Light: PFC contactor open /closed. ON = Closed.

AUX 8 Light: PFC DATA Input. Flashes as data is received.

APPENDIX A: Technical Specifications

CONTACTOR CONTROL:

- Control of all contactor configurations, Inline, Bypass, and Output.
- Deceleration works with all contactor configurations.

RELAY OUTPUTS:

- Eight programmable relays with 16 selections.
- 3 delay on make timers (TON). Can be sent to any relay.
- 1 off delay timer (TOF). Can be sent to any relay.
- Option for up to 24 additional programmable relays with 16 selections.

START / STOP CONTROL:

- Two wire Or Three Wire control.
- Local/ Remote selection > Local = Start /Stop PBs, Remote =Modbus Com. (Interlock 2 used for switch input)
- Modbus Start/Stop with or without a password code.

STATUS:

- Status of all relays, contactors, timer times, and inputs displayed in the HMI and Modbus.

COMMUNICATIONS:

- Rx5 relay and RTD12 can be connected by RS485.
- Customer use Modbus RS485 connection. Customer can read the MVC, TCB, and all connected devices.
- Customer use Modbus TCP/IP Ethernet built in. Customer can read the MVC, TCB, and all connected devices.
- M-Link USB and connection for Bluetooth.

OPTIONS:

- With a Rx5 and in the E-Bypass mode, a complete ATL starter with all functions.
- 3 option slots. Up to 8 relays each slot or PFC option with 4 relays.
- Optimal PFC control with sequential on and off, with and without deceleration.

DATA LOGGING:

- With a Micro SD Card (32GB)

APPENDIX B: Communication Registers

Customer SCADA Modbus Connection TCP/IP (J6 on the TCB CPU) and RTU (J3 on TCB CPU).

Input Registers: Modbus Function 4:

2000 to 2099 = MVC4 Starter

2100 to 2199 = TCB

2200 to 2299 = RTD12 #1 (Optional)

2300 to 2399 = RX5 #1 (Optional)

2400 to 2499 = RTD12 #2 (Optional)

2500 to 2599 = RX5 #2 (Optional)

3000 to 3100 = Commands

MVC4 Starter Data 2000 - 2099

Customer List	
Customer SCADA Modbus RS485 and TCP/IP address:	
2000 to 2099 = MVC4 Starter Data	TCB Address
Metering Page 1	
Ia	2000
Ib	2001
Ic	2002
Gf X .01	2003
Vab	2004
Vbc	2005
Vca	2006
Iavg	2007
Vavg	2008
Motor Load %Fla	2009
GF	2010
Therm Reg Remain	2011
Therm to Start	2012
I/B Amps	2013

Reserved	2014
ITT to Start	2015
Avg Start time	2016
Last Start time	2017
Avg Start Current	2018
Reserved?	2019
Freq	2020
P/F	2021
RPM	2022
Phase Order	2023
Metering Page 2	
P/F Sign	2024
P/F	2025
KWH Used	2026
Kw	2027-28
KVA	2029-30
KVAR	2031-32
MWH Used	2033-34
Peak Kw	2035-36
Peak KVA	2037-38
Peak KVAR	2039-40
Peak Amps	2041-42
Peak Kw time	2043-44
Peak Kva time	2045-46
Peak KVAR time	2047-48
Peak Amp time	2049-50
Metering Page 4	
OL time to trip	2051
Therm Inh time left	2052
Coast Down left	2053-54
Time Between Starts time	2055-56
Start per Hour 0	2057-58

Start per Hour 1	2059-60
Start per Hour 2	2061-62
Start per Hour 3	2063-64
Start per hour 4	2065-66
Start per hour 5	2067-68
Relay Status	2069
Metering Page 6	
Last Trip	2070
Metering Page 7	
MWH Total	2071-72
Running Hours Total	2073
*TE-RTD1(2062) – (2079) if RTD is installed.	2080-2097

*Optional RTD card when installed on the MVC4 CPU. Must be enabled in TCB page 7.

Smart TCB Status 2100 - 2199

START Command	2100
Interlock 1	2101
Interlock 2 / Remote Com	2102
E-Stop	2103
E-Bypass Mode	2104
Fault	2105
Inline Feedback	2106
Bypass Feedback	2107
Output Feedback	2108
Ready	2109
Start Delay	2110
TCB Fault Code Number	2111
ETHERNET ACTIVE>YES/NO	2112
Reserved	2113-2120
Relay Status	
Relay #0-1	2121
Relay #0-2	2122

Relay #0-3	2123
Relay #0-4	2124
Relay #0-5	2125
Relay #0-6	2126
Relay #0-7	2127
Relay #0-8	2128
Relays 1-1 to 3-8 are optional	
Relay #1-1	2129
Relay #1-2	2130
Relay #1-3	2131
Relay #1-4	2132
Relay #1-5	2133
Relay #1-6	2134
Relay #1-7	2135
Relay #1-8	2136
Relay #2-1	2137
Relay #2-2	2138
Relay #2-3	2139
Relay #2-4	2140
Relay #2-5	2141
Relay #2-6	2142
Relay #2-7	2143
Relay #2-8	2144
Relay #3-1	2145
Relay #3-2	2146
Relay #3-3	2147
Relay #3-4	2148
Relay #3-5	2149
Relay #3-6	2150
Relay #3-7	2151
Relay #3-8	2152
Start in Progress	2153
Reserved	2154-2159
Slot #1 Option Type	2160
Slot #2 Option Type	2161
Slot #3 Option Type	2162

Timer 1 Time Remaining	2163
Timer 2 Time Remaining	2164
Timer 3 Time Remaining	2165
Timer 4 Time Remaining	2166
Start Delay Timer, Time Remaining	2167
RTC Year	2168
RTC Month	2169
RTC Day Date	2170
RTC Week Day	2171
RTC Hour	2172
RTC Min	2173
RTC Sec	2174
S/N	2175
Firmware #	2176

TE-RTD12 #1 2200- 2299

Hottest Stator ID	2200
Hottest Stator Temperature	2201
Hottest Non-Stator ID	2202
Hottest Non-Stator ID Temperature	2203
Stator 1 Temperature	2204
Stator 2 Temperature	2205
Stator 3 Temperature	2206
Stator 4 Temperature	2207
Stator 5 Temperature	2208
Stator 6 Temperature	2209
Front Bearing Temperature	2210
Rear Bearing Temperature	2211
Bearing Box Temperature	2212
Ambient Temperature	2213
TE-RTD12 Temperature	2214
TE-RTD12 Temperature	2215

RX-5 #1 2300- 2399

Thermal Capacity	2300
Phase A Current	2301
Phase B Current	2302
Phase C Current	2303
Average Current	2304
Current Imbalance	2305
Line AB Voltage	2306
Line BC Voltage	2307
Line CA Voltage	2308
Average Voltage	2309
Voltage Imbalance	2310
Power Factor	2311
Kilo/Mega Watt	2312
Kilo/Mega VA	2313
Kilo/Mega VAR	2314
Kilo/Mega Watt Hours	2315
Frequency	2316
Ground Fault Current	2317

TE-RTD12 #2 2400- 2499

Hottest Stator ID	2400
Hottest Stator Temperature	2401
Hottest Non-Stator ID	2402
Hottest Non-Stator ID Temperature	2403
Stator 1 Temperature	2404
Stator 2 Temperature	2405
Stator 3 Temperature	2406
Stator 4 Temperature	2407
Stator 5 Temperature	2408
Stator 6 Temperature	2409
Front Bearing Temperature	2410
Rear Bearing Temperature	2411
Bearing Box Temperature	2412

Ambient Temperature	2413
RTD11 Temperature	2414
RTD12 Temperature	2415

RX-5 #2 2500- 2599

Thermal Capacity	2500
Phase A Current	2501
Phase B Current	2502
Phase C Current	2503
Average Current	2504
Current Imbalance	2505
Line AB Voltage	2506
Line BC Voltage	2507
Line CA Voltage	2508
Average Voltage	2509
Voltage Imbalance	2510
Power Factor	2511
Kilo/Mega Watt	2512
Kilo/Mega VA	2513
Kilo/Mega VAR	2514
Kilo/Mega Watt Hours	2515
Frequency	2516
Ground Fault Current	2517

Register Address: 3000 - 3002

Remote Start/Stop

Register 3000

Function code 3

Depends on TCB Page 4 settings:

Enabled =

0=Stop

1=Start

Code Required =

0=Stop

Start Code = Start, See 3001 below.

Request Start Code

Register 3001

Function code 3

NOTE: Each start requires a new code.

R/O If Remote Start set to Code Required:

Request Start Code by reading 3001, then Reply with Start Code to address 3000 to start.

0 to Stop.

Operates the Programmable Relay;

3002 Operates the Programmable Relay when relay is set to ON-Off by 3002 in TCB page1.

0- Opens Relay

1- Closes Relay

Warranty information

1 Year Warranty: Phasetronics Inc., dba Motortronics, (hereinafter “Company”) warrants the **Msmart** product to be free from defects in material and/or workmanship for a period of one (1) year from the date of sale, or a maximum of 18 months from the date of manufacture (if no sales records are available) as indicated by the unit’s date code. The Company reserves the right to repair or replace any malfunctioning units or sub- assemblies under warranty at the Company’ sole option. Warranty repairs may be performed at the Company’s facility, in the field by a factory-authorized technician, or by the customer only with prior approval and at the specific direction of the Company’s Technical Services personnel. During the 1 year period, malfunctions of the control boards will be dealt with by replacement of the Modular Control Assembly (MCA), which contains the User Interface Panel, Digital Control Unit, Bypass control (if any) and Communications Interface. The MCA is designed to be replaced quickly without the need for tools (plug-in), and as such will constitute the majority of warranty replacements.

Warranty Service Procedure:

In the event that warranty service becomes necessary, contact the distributor where the starter was purchased, or Motortronics Technical Services department directly at (727) 573-1819. Be prepared to provide the complete Model number, Serial Number, Firmware Number, date and place of purchase. It is also helpful to know the date of initial commissioning. When Technical Services has determined the nature of the problem and that sending replacement parts or assemblies can repair it, they will require a purchase order for replacement parts and issue a Return Material Authorization (RMA) for the defective parts or assemblies. If any components or assemblies are received at the factory without the proper RMA documentation, the shipment(s) will be refused.

When the replacement parts are received and evaluated at the factory, any warranty determination will result in an offsetting credit being issued for the replacement parts already sent out. If the unit is not needed for immediate operation, an alternative is to have the Technical Services representative provide an RMA for the components, and they will be evaluated and repaired at the factory, and returned. In either circumstance, freight/shipping costs are the responsibility of the purchaser.

Responsibility:

Company is not responsible for the misuse or misapplication of its products, intentional or otherwise. Improper application, installation, failure to provide safety devices or protective measures, or operation above its ratings, and failure to properly maintain or service products are all beyond the control and responsibility of the Company. Under no circumstances shall the Company be liable for loss of profits, indirect, incidental, special, consequential or other similar damages arising out of the misuse, misapplication or failure to maintain the

California Customers:

California Proposition 65 Warning

WARNING: this product and associated accessories may contain chemicals known to the State of California to cause cancer, birth defects, or other reproductive harm. For more information visit <https://p65warnings.ca.gov>



MOTORTRONICS™

Solid State AC Motor Control

Msmart

SMART-TCB Addendum

Phasetronics, Inc. dba Motortronics
1600 Sunshine Drive
Clearwater, Florida 33765
USA

Tel: +1 727.573.1819 or 888.767.7792
Fax: +1 727.573.1803 or 800.548.4104

www.motortronics.com